



Brakes for the  
Stage equipment





## FDD Double Brake

FDD double brakes are two specially designed low noise brakes working independent of each other meeting high demands of safety.

As option (M) a microswitch is monitoring the function of each brake. The design homologation in accordance with EN 81 and BGV for elevator brakes has been granted.

As standard the brakes are equipped with a special one hand operated manual hand release and tapped bores for encoder mounting.

### Options:

- Micro switch for monitoring function (Option M)
- Friction plate (Option R) or adapter flange (Option F)

Size	Mb (Nm) 7 Springs	Mb (Nm) 5 Springs reduced	Mb (Nm) 4 Springs reduced	P 20°C (Watt)	a	b1	b2	c	Toothed hub d1 H7 / d2 H7	d3	d4	d6 H7	d7
08	2 x 6	2 x 4	2 x 3,5	2 x 22	0,2 <sup>+0,15</sup>	6	9,5	34,5	11/12/15*	42	59,8	26	85
10	2 x 12,5	2 x 8,5	2 x 7	2 x 28	0,2 <sup>+0,15</sup>	7	10,5	47	11/12	50	78	32	105
13	2 x 25	2 x 17,5	2 x 14	2 x 34	0,3 <sup>+0,15</sup>	9	12,5	37,5	15/20	62	96	42	130
15	2 x 50	2 x 35	2 x 28	2 x 42	0,3 <sup>+0,15</sup>	9	12,5	42	20/25	80,5	117	52	150
17	2 x 75	2 x 52	2 x 42	2 x 50	0,3 <sup>+0,15</sup>	11	13,5	46	25/30/35*	93	126	62	170
20	2 x 125	2 x 89	2 x 70	2 x 64	0,4 <sup>+0,15</sup>	11	13,5	53	30/35/40	118	152	72	195
23	2 x 187	2 x 132	2 x 107	2 x 76	0,4 <sup>+0,15</sup>	11	19	58	35/40/45	127	176	80	225
26	2 x 300	2 x 225	2 x 150	2 x 100	0,5 <sup>+0,2</sup>	11	19	62	40/45/50	153	201	90	258
30	2 x 500	2 x 375	2 x 250	2 x 140	0,5 <sup>+0,2</sup>	19	17	63,5	50/55/60	205	255	115	306
40**	2 x 1200	2 x 1000	2 x 800	2 x 138	0,6 <sup>+0,2</sup>	17	19***	82,5	65/70/75	258	330	150	400

Dimensions in mm, Standard-keyway in accordance with DIN 6885/1 - JS9

\* Keyway in accordance with DIN 6885/3 - JS9, \*\* 12/10/8 springs

\*\*\* no design with friction plate; penetration depth and/or thickness for design with flange

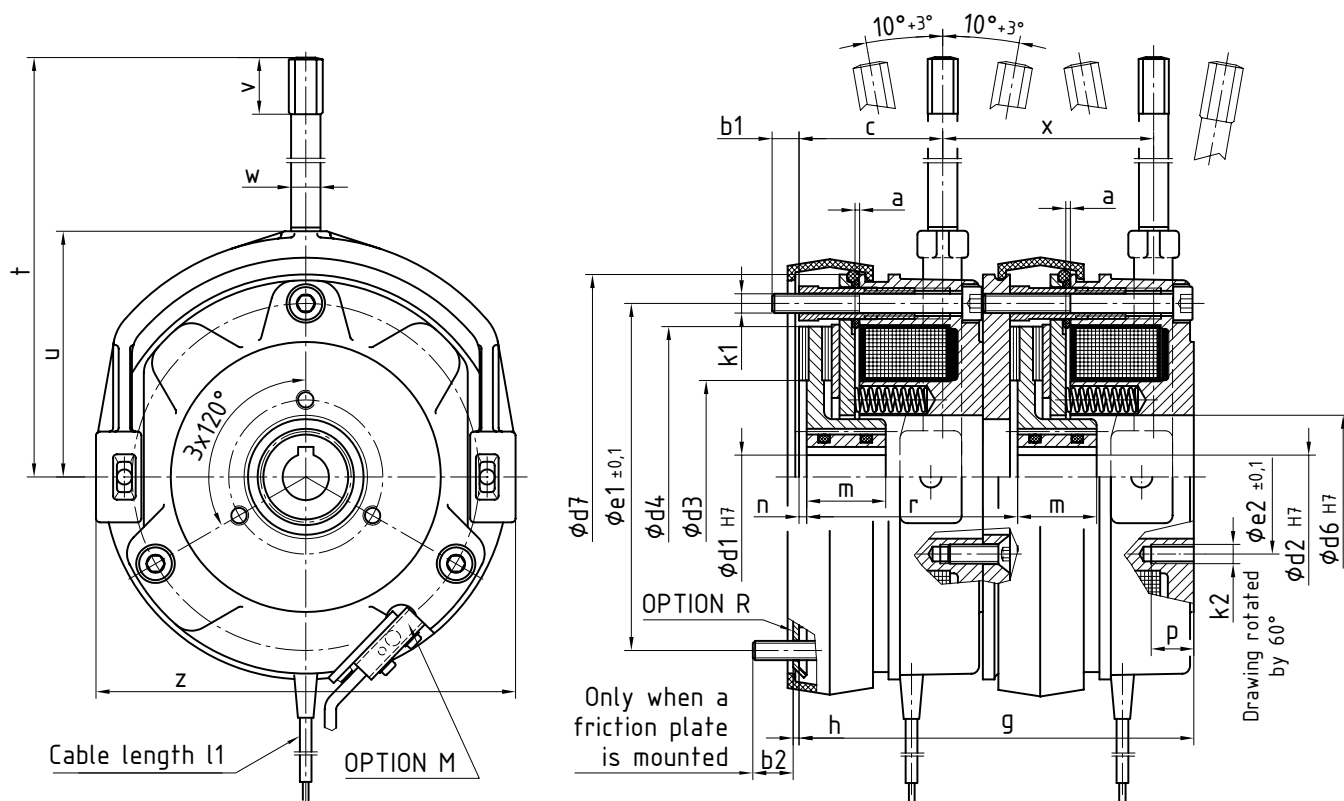

Size	$\phi e1 \pm 0,1$	$\phi e2 \pm 0,1$	g	h	k1	k2	l1	n	m	p	r	t	u	v	w	x	z
08	72	34	82,6	1,5	3 x M4	3 x M4	800	1,5	18	8	44,3	110	55	15	8	44,3	89
10	90	40	102,4	1,5	3 x M5	3 x M5	800	2,5	20	12	54,5	120	65	15	8	54,5	111
13	112	54	115,2	1,5	3 x M6	3 x M6	800	3,5	20	12	62	160	75	20	10	62	132
15	132	65	129,6	1,5	3 x M6	3 x M6	800	3	25	12	69	200	85	20	10	69	151
17	145	75	150,6	2	3 x M8	3 x M8	800	3	30	15	81	220	97	25	12	81	172
20	170	85	171,8	2	3 x M8	3 x M8	1000	3	30	15	91	220	116	25	12	91	196
23	196	95	190,6	2	3 x M8	3 x M8	1000	4,5	35	15	101	250	128	25	12	101	224
26	230	110	208,8	2	3 x M10	6 x M10	1000	4	40	25	110	330	148	35	19	110	258
30	278	138	220	2	6 x M10	6 x M10	1000	4	50	25	115,5	357	175	35	19	115,5	304
40	360	180	259,2	18***	6 x M12	6 x M12	1000	4	70	43	138,5	415	230	35	19	138,5	403

Dimensions in mm, Standard-keyway in accordance with DIN 6885/1 - JS9

\* Keyway in accordance with DIN 6885/3 - JS9, \*\* 12/10/8 springs

\*\*\* no design with friction plate; penetration depth and/or thickness for design with flange

## Company Information



Headquarters and Assembly Line at Bückeberg-Röcke



Plant - CNC Production at Bückeberg-Müsing



Plant - Helpsen

PRECIMA Magnettechnik GmbH was founded in the year 1981 and is today established as an independent, medium sized, innovative family owned brake manufacturer. With our staff of more than 160 employees we develop and produce a wide range of electro-magnetic operated brakes and clutches for all kinds of applications in machine and other industries. Our standard range of products covers a performance scope of braking torques between 0.5 and 1,600 Nm.

Thanks to our advanced CNC machining technology and well organized assembly lines we produce more than 550,000 units per year. The high rate of self manufactured parts provides us with a maximum of flexibility and allows for short response times. Our own highly qualified and experienced engineering and development departments are specialized in producing customized brake solutions on a very high technical and economic standard.

### PRECIMA MAGNETTECHNIK GmbH

Röcker Straße 16  
31675 Bückeberg / Germany  
Tel.: ++49(0)5722 89332-0  
Fax: ++49(0)5722 89332-2  
E-Mail: [info@precima.de](mailto:info@precima.de)

[www.precima.de](http://www.precima.de)

